



# **5000 Gypsy/Drum Windlass Installation Manual**

**Issue B**

**LEWMAR<sup>®</sup>**

---

## ***PART 1 - HYDRAULIC ANCHOR WINDLASS INSTALLATION***

### **VERTICAL HYDRAULIC MODELS**

- Windlass Installation**
- 1 Remove the anchor windlass from the packing case. Ensure that you have the necessary parts required to complete your system.  
  
There are three items to position, the windlass, chain pipe (optional) and controls. Remember to allow space below deck for the motor - gearbox and for the connection of the hydraulic lines from the windlass to the power unit.
  - 2 Position the windlass deck unit on the deck or in the anchor well (see drawings for cut out dimensions) such that the centre - line of the chain on the gypsy aligns with the bow roller in a horizontal plane, and that the vertical line is within 10 degrees of the chain gypsy. Ensure that the chain achieves maximum contact around the chain gypsy (i.e. at least 120 and preferably 180 degrees contact).
  - 3 Cut and drill clearance holes in the deck for the windlass and chain pipe, to the size detailed on the installation template.
  - 4 Apply bedding compound onto the joint faces and mount the windlass and chain pipe with the gypsy facing pawl facing aft and the chain stripper facing forward.

# LEWMAR®

---

## Hydraulic Installation

- 5 The Lewmar 5000 hydraulic windlass is designed to be used with Lewmar Commander power packs or similar power packs that give the required flow and pressure. Plan the routing of the hydraulic lines **(including case drain lines)** and run them from the hydraulic supply to the windlass motor (see hose type recommendations).
- 6 Connect the hydraulic feed and return lines to the hydraulic windlass motor, ensuring that the connections are secure (see motor specifications).
- 7 Connect the case drain line (see case drain line specifications).
- 8 Find a suitable position for electric safety deck switch(es), remote control and / or toggle switch in view of the windlass, anchor line and bow roller. Connect up the switch wiring to the Commander system (see Commander manual) or a suitable proprietary system ensuring that the minimum supply is 3 amps. The switches require a 12V or 24V DC system depending on available supply.
- 9 Check correct operation of the windlass (eg up / down).  
  
If the rotation is incorrect swap the A + B hoses at the motor, or swap the switch wiring, or swap the Directional Control Valve (DCV) caps.

# LEWMAR®

---

## **ANCHOR WINDLASS HYDRAULIC SPECIFICATIONS**

### **CUSTOM 5000 VERTICAL HYDRAULIC MODELS**

#### **Hydraulic Motors**

The hydraulic motor is a fully reversible, high efficiency motor gearbox.

<b>Model</b>	<b>Motor</b>	<b>Flow Min / Max (Ltr / min)</b>	<b>Pressure Max (Bar)</b>
5000	150 cc/Rev	20 - 40	140 (2030 psi)

**Note:** (a) 3.78 litres  $\approx$  1 US Gallon  
4.54 litres  $\approx$  1 Imperial Gallon  
(b) 14.5 psi = 1 Bar

#### **Anchor Windlass Specifications**

<b>Model</b>	<b>Max Pull</b>	<b>Max Line Speed</b>	<b>Working Load</b>
5000	2275 kg 5015 lb	9-19 m (31-63 ft) / min	454 kg 1000 lb

<b>Model</b>	<b>Line Speed @ Working load</b>	<b>Weight</b>
5000	Dependant on Power Pack	125 kg / 275 lb

# LEWMAR®

---

## Hose Types

For reliable operation and safety reasons, it is essential to use the correct bore size of hose. To reduce pressure drops in hose runs greater than 5 - 7 m it is recommended a larger hose size is used.

The recommended hose bore sizes with their flow requirements are given below.

Model	Motor	Flow (Ltr / min)	Min Bore Size
5000	150 cc/Rev	Up to 20 Up to 40	1/2" 3/4 "

- Note:** (a) 3.78 litres  $\approx$  1 US Gallon  
4.54 litres  $\approx$  1 Imperial Gallon  
(b) It is important that the correct hose specification is used as this affects the efficiency of the hydraulic motor and the performance of the windlass.

# LEWMAR®

---

## **IMPORTANT**

### **Drain Line**

To obtain optimum shaft life a case drain line **must** be fitted.

Min drain line bore diameter: 6mm (1 / 4")

Safe working pressure: 18 Bar (250 psi)

All drain lines should if possible be connected to the reservoir separately.

### **Hydraulic Fittings**

The Lewmar Anchor Windlass hydraulic motors accept the following fittings:

Motor ports - 1/2" BSP Female

Case Drain - 1/4" BSP Female

### **Hydraulic Connections**

The connection of the service lines should be plumbed in as follows: -

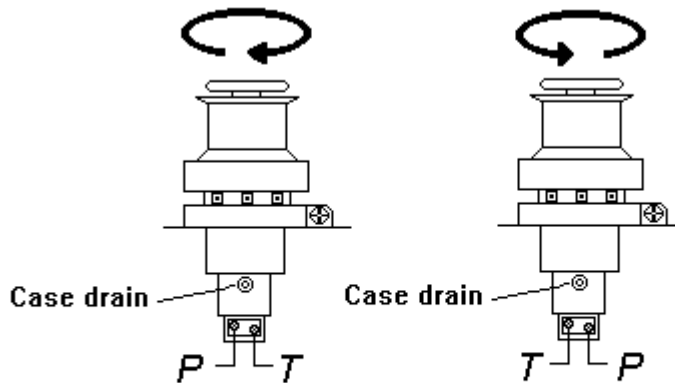

**A Case Drain Line Must Be Fitted.**

## ***PART 2 - OPERATION, MAINTENANCE.***

### **CUSTOM 5000**

### **OPERATION OF VERTICAL HYDRAULIC MODELS**

#### **Operation Explained**

The main shaft, driven by the motor / gearbox, is splined directly to the capstan. The gypsy can either be powered by the capstan or free running. The gypsy is powered by engaging the dog drive teeth of the capstan to the those of the gypsy. Engagement and disengagement of the dog drive is controlled by turning the top nut, which lifts and lowers the capstan. Spring loading between the capstan and gypsy facilitates engagement / disengagement.

The free running gypsy is controlled by tightening or loosening the full wrap brake band. A pawl is available for short-term gypsy locking when the capstan is used independently.

#### **Power Up**

Press the deck switch, remote control or toggle switch (Anchor Up).

NOTE: Ensure that the brake band and gypsy pawl are released and that the dog drive is fully engaged.

#### **Power Down**

Press the deck switch, remote control or toggle switch (Anchor Down).

NOTE: Ensure that the brake band and gypsy pawl are released and that the dog drive is fully engaged.

#### **Manual Chain Release**

Place a Lewmar winch handle in the brake band bi - square and secure the chain gypsy. Place the Lewmar winch handle into the top nut and raise the capstan until the dog drive is fully disengaged.

Replace the handle in the brake band bi - square and carefully release the brake to allow the gypsy to run free. The descent of the chain can be controlled and stopped by tightening the band.

# LEWMAR®

---

## **Capstan Operation**

Gypsy/Capstan model - To use the capstan (with rope only) lock the gypsy off with the brake band or pawl to stop the chain from free running. Place a Lewmar winch handle into the top nut and raise the capstan until the dog drive is fully disengaged.

Press the Up button to power the Capstan.

## **Dog Drive Engagement**

Place a Lewmar winch handle into the top nut and lower the capstan down onto the gypsy until resistance is felt, then backwind one quarter of a turn.

Press the Up/Down switch and the dog drive will spring down into positive engagement. Tighten down the top nut securely if required.

Once the dog drive has been fully engaged, stop power operation and release the brake band or gypsy pawl before powered operation is continued.

### ***Warning !***

**Ensure that the dog drive is fully engaged when powering in or out.**

**Keep hands and feet clear of free running chain.**

**Do not leave a winch handle in the windlass while operating.**

Classification society rules require that a vessel lying at anchor should have its chain held by a cable / chain stopper or equivalent strong point as a windlass should not be subjected to the loads generated under storm conditions.

We recommend that the vessels engine should always be used to aid anchor recovery.

Do not attempt to pull a load greater then the rated load of the windlass.

When the windlass is not in use the anchor must be tied off onto a cleat or equivalent strong point to prevent damage to the vessel.

## **Maintenance**

The windlass is housed in the harshest environment on the vessel. The windlass should be checked and cleaned every six months. Wash away salt deposits using fresh water, clean and grease the main shaft, spline and bearings (using a marine grade grease).

Remove the brake band assembly, clean brake band and gypsy (**Do not allow grease onto the brake band surface**). Check for wear and replace if necessary.

Check the motor / gearbox for signs of corrosion. If corrosion is evident, clean and repaint with a marine grade oil based enamel paint.

# LEWMAR®

---

## **PART 3 - PARTS LIST AND TECHNICAL DRAWINGS**

### **SPARE PARTS LIST**

<b>5000 Windlass</b>	<b>Part No</b>	<b>Description</b>	<b>Qty</b>
	15001349	Gypsy Bearing Washer	1
	15001492	Pillar Band Support	1
	15001494	Washer	1
	15008007	Roller Bearing	6
	18000020	Bearing Assembly	2
	60000327	Hyd Motor/Gearbox 5000 AW	1
	65000154	Sleeve	4
	65000202	Chain Stripper	1
	65000203	Band Brake Support Plate	1
	65000204	Pawl	1
	65000205	Pawl Pillar	2
	65000206	Fixed Band Brake Pin	1
	65000207	Moving Band Brake Pin	1
	65000208	Band Brake Cover	1
	65000209	Adjusting Screw	1
	65000211	Centre Stem	1
	65000212	Base	1
	65000213	Drive Shaft	1
	65000214	Cleat Nut	1
	65000215	Shoulder Screw	1
	65000216	Retaining Sleeve	1
	65000217	Drum	1
	65000218	Collet	1
	65000224	Stripper Support Pin	2
	65000692	Washer Tag	1
	68000111	5000 A / W Brake Band Assy	1
	B1555	Ball Spring	2
	B1798	Spring	4
	B2787	Seal 45x60x7	1
	B7794	Circlip Internal	2
	B7799	Circlip External (3" H / Duty )	1
	B8314	O Ring 92mm	1
<b>Gypsy Kits</b>	68000099	Gypsy Kit 401	
	68000173	Gypsy Kit 402	
	68000174	Gypsy Kit 403	
	68000463	Gypsy Kit 404	

# 4000/5000 HYDRAULIC ANCHOR WINDLASS

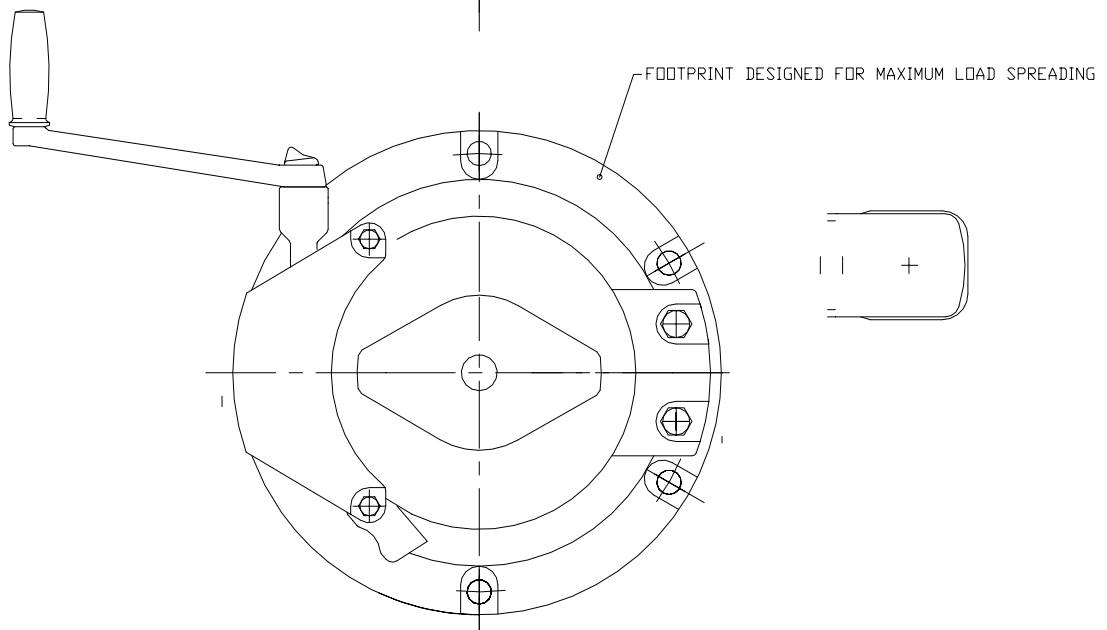
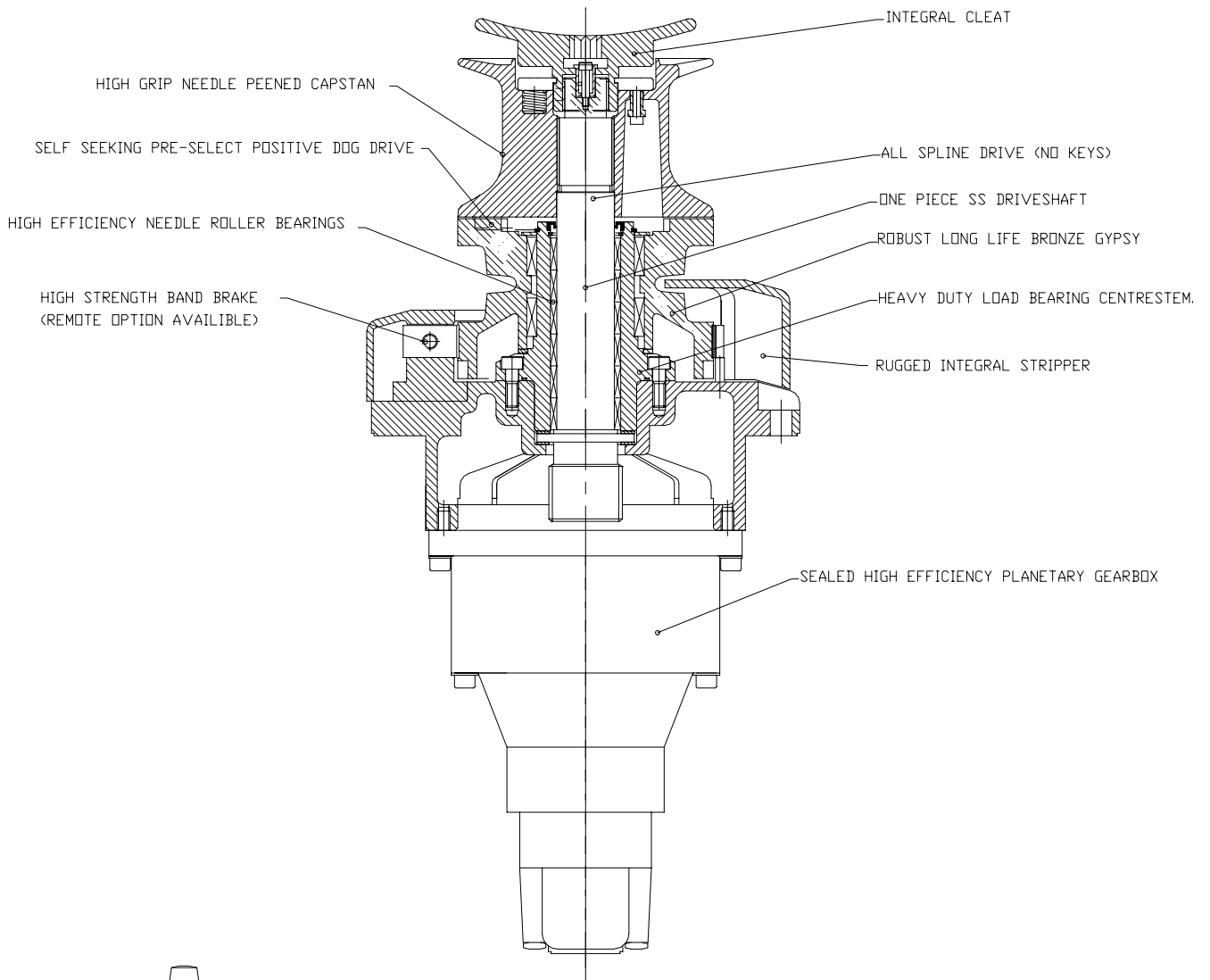

# 5000 ANCHOR WINDLASS

## HYDRAULIC

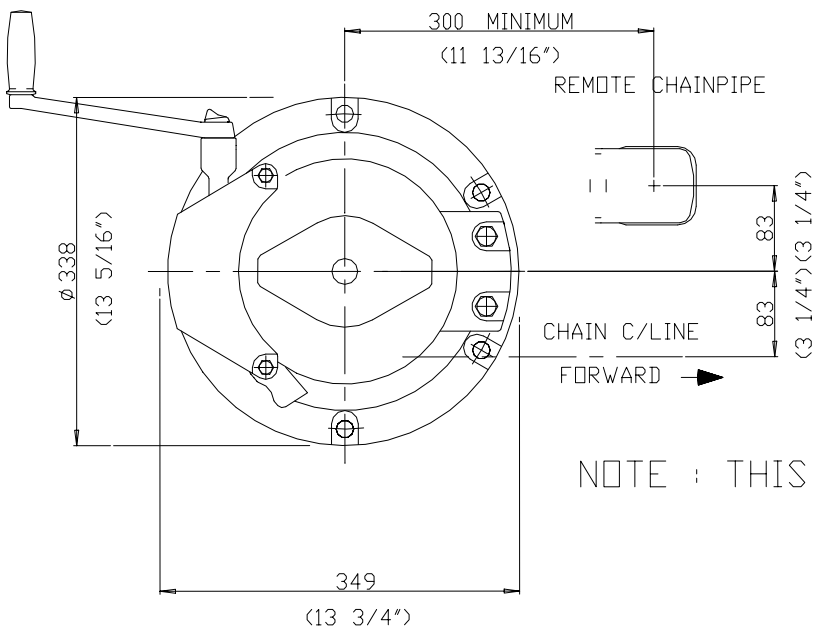
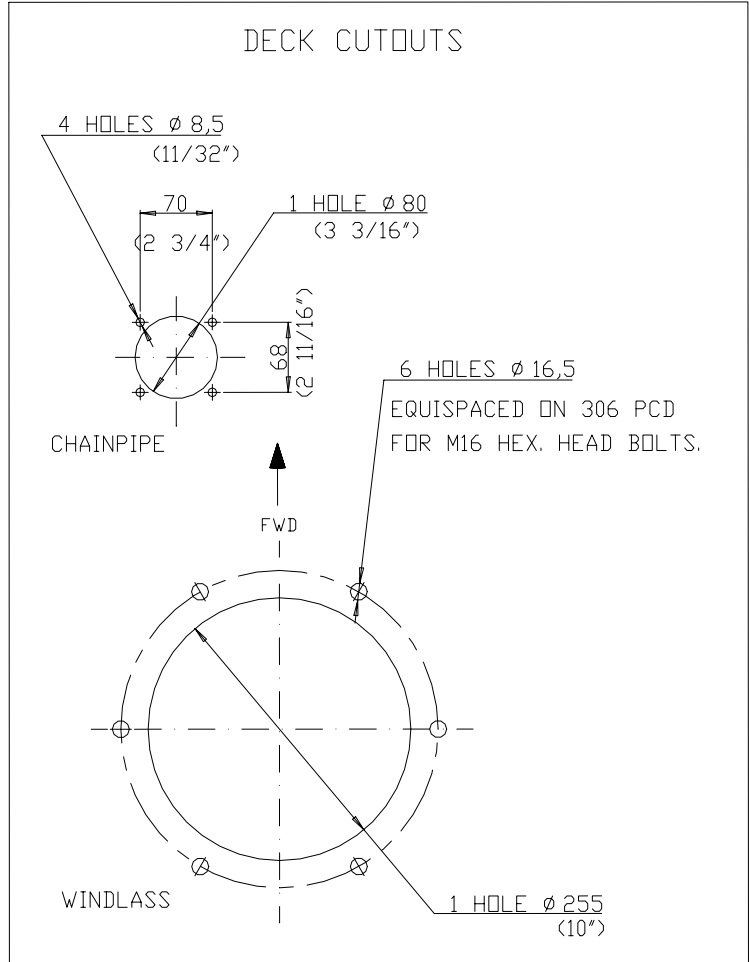
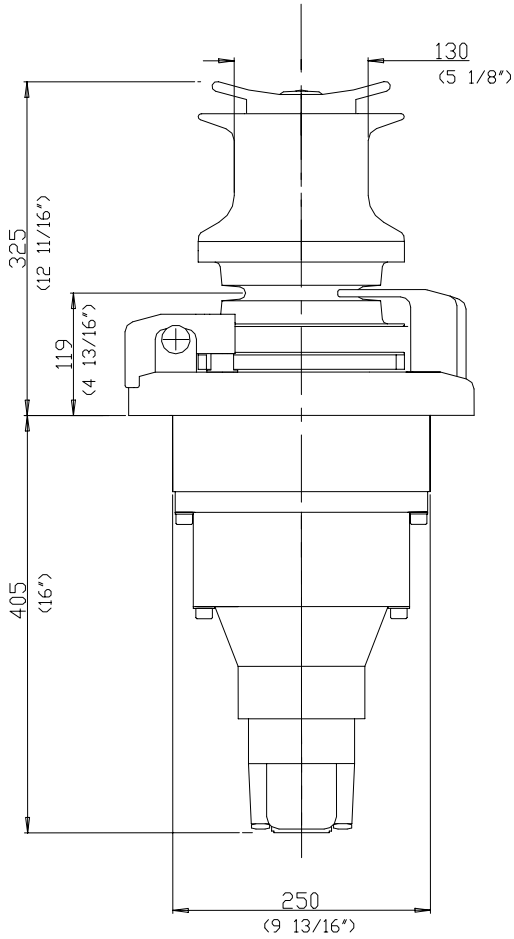

NOTE : THIS IS LEFT HAND VERSION

DRN	A.MCC.	DRG. No	WSD0335	<b>LEWMAR</b>
DATE	08.03.94			

4 HOLES: M6 X 1.0-6H  
X 12 DEEP FULL THREAD

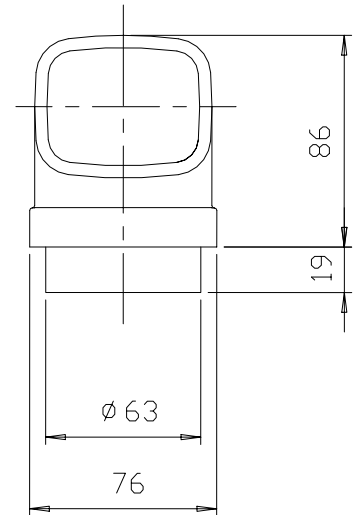
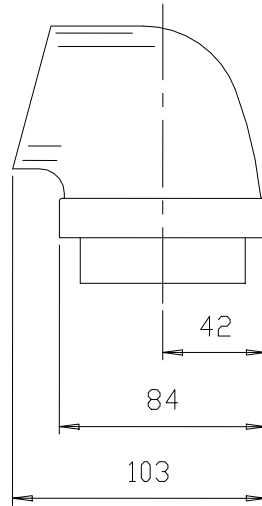
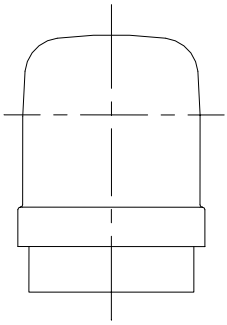
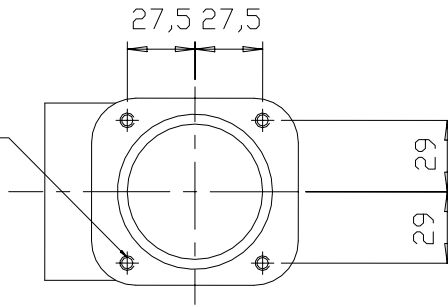

8-13mm REMOTE CHAINPIPE  
68000024

4 HOLES: M8 X 1.25-6H  
X 14 DEEP FULL THREAD

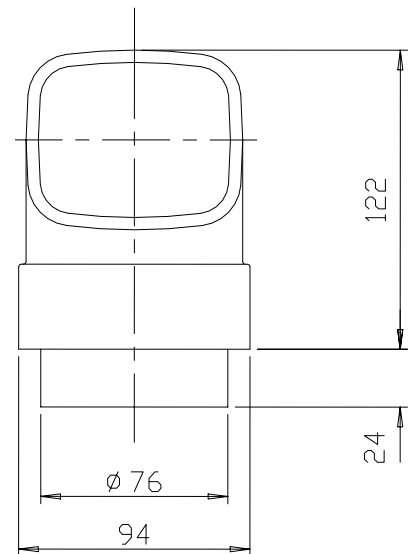
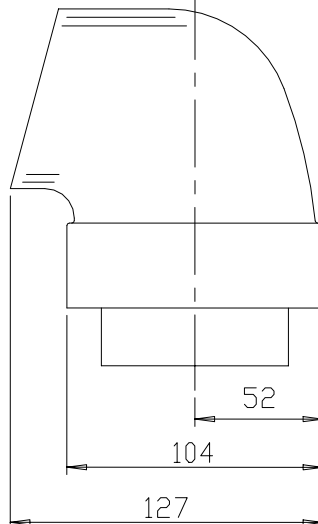
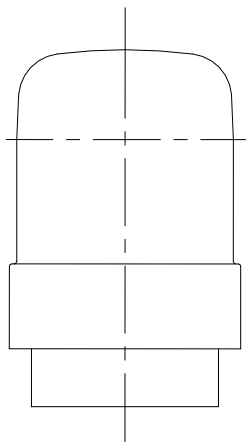
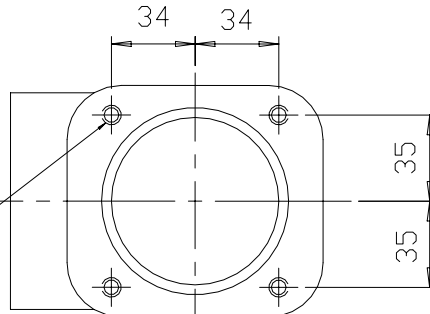

14-16mm REMOTE CHAINPIPE  
68000037 - CH

680000314 - BR

DRN	AMCC.
DATE	21.02.94

DRG. No	WSD0237
---------	---------

**LEWMAR**

WINDLASS MODEL	3500 ANCHOR WINDLASS				4000/5000 ANCHOR WINDLASS			WINDLASS MODEL
GYPSY IDENT. NO	351	352	353	354	401	402	403	GYPSY IDENT. NO
GYPSY KIT NO.	68000574	68000575	68000576	68000577	68000099	68000173	68000174	GYPSY KIT NO.
GYPSY KIT - CONCEPT [ARM] - FEB.96								
GYPSY KIT. OCEAN - FEB.96								
1/4" BRADNEY GRADE 40								1/4" BRADNEY GRADE 40
1/4" ACCO GRADE 40								1/4" ACCO GRADE 40
8mm GUNNEBO								8mm GUNNEBO
8mm SWEDISH								8mm SWEDISH
8mm FRENCH/ITALIAN								8mm FRENCH/ITALIAN
8mm BRADNEY								8mm BRADNEY
8mm DIN766								8mm DIN766
5/16" ACCO GRADE 40								5/16" ACCO GRADE 40
5/16" ACCO BBB								5/16" ACCO BBB
5/16" MARLOW								5/16" MARLOW
5/16" CAMPBELL SYS.3								5/16" CAMPBELL SYS.3
5/16" CAMPBELL SYS.4								5/16" CAMPBELL SYS.4
9,2mm GUNNEBO								9,2mm GUNNEBO
10mm DIN766	*							10mm DIN766
10mm HACKET								10mm HACKET
10mm FRENCH/ITALIAN	*							10mm FRENCH/ITALIAN
10mm ISO 4565	*							10mm ISO 4565
10mm AP LIFTING GEAR	*							10mm AP LIFTING GEAR
10mm RKH DIN766	*							10mm RKH DIN766
10mm BRADNEY GRADE T	*							10mm BRADNEY GRADE T
3/8" ACCO GRADE 80	*							3/8" ACCO GRADE 80
3/8" ACCO GRADE 40	*							3/8" ACCO GRADE 40
3/8" ACCO BBB	*							3/8" ACCO BBB
3/8" CAMPBELL SYS.3	*							3/8" CAMPBELL SYS.3
3/8" CAMPBELL SYS.4	*							3/8" CAMPBELL SYS.4
3/8" MARLOW	*							3/8" MARLOW
3/8" BRADNEY GRADE 30	*							3/8" BRADNEY GRADE 30
3/8" BRADNEY GRADE 40	*							3/8" BRADNEY GRADE 40
11mm DIN766	*							11mm DIN766
12mm DIN766		*			*			12mm DIN766
12mm FRENCH/ITALIAN		*			*			12mm FRENCH/ITALIAN
12mm DUTCH/ITALIAN		*			*			12mm DUTCH/ITALIAN
12mm ISO 4565		*			*			12mm ISO 4565
12mm LEWMAR CHAIN		*			*			12mm LEWMAR CHAIN
13mm DIN766		*			*			13mm DIN766
13mm BRADNEY GRADE T			*		*			13mm BRADNEY GRADE T
13mm RKH DIN766		*			*			13mm RKH DIN766
7/16" ACCO GRADE 40		*			*			7/16" ACCO GRADE 40
7/16" BRADNEY 30		*			*			7/16" BRADNEY 30
7/16" CAMPBELL SYS.4		*			*			7/16" CAMPBELL SYS.4
1/2" BRADNEY GRADE 30			*		*			1/2" BRADNEY GRADE 30
1/2" BRADNEY GRADE 40			*		*			1/2" BRADNEY GRADE 40
1/2" CAMPBELL SYS.3			*		*			1/2" CAMPBELL SYS.3
1/2" CAMPBELL SYS.4		*			*			1/2" CAMPBELL SYS.4
1/2" ACCO GRADE 40			*			*		1/2" ACCO GRADE 40
1/2" ACCO BBB		*			*			1/2" ACCO BBB
1/2" ACCO GRADE 80			*			*		1/2" ACCO GRADE 80
14mm ISO 4565				*		*		14mm ISO 4565
14mm MULTIFAST				*		*		14mm MULTIFAST
14mm BRADNEY SHORTLINK				*		*		14mm BRADNEY SHORTLINK
14mm DIN766			*		*			14mm DIN766
9/16" ACCO BBB				*		*		9/16" ACCO BBB
5/8" ACCO GRADE 40						*		5/8" ACCO GRADE 40
CIM 16mm							*	CIM 16mm

## WINDLASS CHAIN CHART

NOTE  
1. GYPSY KIT \* - CONCEPT ONLY - PRIOR TO FEB. 96

DRN	A.M.C.C.	DRG. No
DATE	08.02.96	WSD0670

**LEWMAR**

## **LEWMAR LIMITED WARRANTY**

Lewmar warrants its products in normal usage to be free of defects in materials and workmanship for a period of three years from date of purchase by the original purchaser, subject to the conditions, limitations and exceptions listed below. Any part, which proves to be defective in normal usage during that three-year period, will be repaired or at Lewmar's option, replaced by Lewmar.

### **A CONDITIONS AND LIMITATIONS**

- i Lewmar's liability shall be limited to repair or replacement of the goods or parts defective in materials or workmanship.
- ii Determination of the suitability of the material for the use contemplated by the buyer is the sole responsibility of the buyer and Lewmar shall have no responsibility in connection with such suitability.
- iii Lewmar shall not be liable in any way for:
  - a Failures, loss or damage due to use of products in applications for which they are not intended.
  - b Failures, loss or damage due to corrosion, ultra violet degradation, wear and tear or improper installation.
  - c Failures, loss or damage due to incorrect maintenance.
  - d Failures, loss or damage due to conditions that exceed the product's performance specifications.
- iv Product subject to warranty claim must be returned to Lewmar for examination unless otherwise agreed by Lewmar in writing.
- v Lewmar shall not be responsible for shipping charges nor installation labour associated with any warranty claim.
- vi Service by anyone other than authorised Lewmar representatives shall void this warranty unless it accords with Lewmar guidelines and standards of workmanship.
- vii Lewmar's products are intended for use only for marine purposes. Buyers intending to use them for any other purpose should seek advice from Lewmar, and Lewmar shall be under no liability arising from use, which Lewmar has not approved.

### **B EXCEPTIONS**

Warranty is limited to a period of one year from the date of purchase in the case of the following:

- Bow thrusters
- Electric motors and electrical equipment
- Electronic controls
- Hydraulic pumps, valves and actuators
- Weather seals
- Products used in "Grand Prix" racing applications

C LIABILITY

- i Lewmar's liability under this warranty shall be to the exclusion of all other warranties or liabilities (to the extent permitted by law). In particular (but without limitation):
  - a Lewmar shall not be liable for:
    - Any indirect or consequential loss including (without limitation) any loss of anticipated profits, damage to reputation or goodwill, loss of expected future business, damages, costs or expenses payable to any third party or any other indirect losses.
    - Any damage to yachts or equipment.
    - Death or personal Injury (unless caused by Lewmar's negligence).
  - b Lewmar grants no warranties regarding the fitness for purpose, use, nature or satisfactory quality of the goods.
- ii Where the laws of the country do not permit a warranty to be excluded, then such warranty, if permitted by that country's law, shall be limited to a period of one year.

## **LEWMAR CONTACT DETAILS**

### **LEWMAR SALES OFFICES**

#### **Lewmar UK/Rest of World**

Lewmar Ltd, Southmoor Lane, Havant, Hampshire PO9 1JJ. UK

Tel (+44) 23 92 485700 Fax (+44) 23 92 485710

e-mail [info@uk.lewmar.com](mailto:info@uk.lewmar.com)

#### **Lewmar USA**

Lewmar Inc, New Whitfield Street, Guilford, CT 06437, USA

Tel (+1) 203 458 6200 Fax (+1) 203 453 5669

e-mail [info@usa.lewmar.com](mailto:info@usa.lewmar.com)

#### **Lewmar Mid Europe**

Lewmar Ltd, Branderweg 19, 8042 PD Zwolle, The Netherlands

Tel (+31) 38 427 34 90 Fax (+31) 38 421 56 42

e-mail [info@holland.lewmar.com](mailto:info@holland.lewmar.com)

#### **Lewmar Southern Europe**

Lewmar Ltd, Place Bernard Moitessier, 17000 La Rochelle, France

Tel (+33) 5 46 50 50 46 Fax (+33) 5 46 50 59 04

e-mail [info@france.lewmar.com](mailto:info@france.lewmar.com)

#### **Lewmar Southern Europe (Cannes)**

Lewmar Ltd, Allée Charles Nungesser, Parc D'Activités de la Siagne 06210 Mandelieu, France

Tel (+33) 4 93 48 80 48 Fax (+33) 4 93 48 37 50

e-mail [info@france.lewmar.com](mailto:info@france.lewmar.com)

#### **Lewmar Southern Europe (Spain)**

Lewmar Ltd, Sucursal en Espana, Joan de Borbó 92,

08039 Barcelona, Spain

Tel (+34) 93 221 94 37 Fax (+34) 93 225 19 49

e-mail [info@spain.lewmar.com](mailto:info@spain.lewmar.com)

#### **Lewmar Northern Europe**

Lewmar Marin AB, Argongatan 8, S-431 53, Mölndal, Sweden

Tel (+46) 31 277130 Fax (+46) 31 273116

e-mail [info@sweden.lewmar.com](mailto:info@sweden.lewmar.com)

#### **Lewmar Northern Europe (Finland)**

Lewmar Marin AB (Finland), Laaksoitie 10 A-B, 02700 Kauniainen, Finland

Tel (+358) 9 5489 5110 Fax (+358) 9 5489 5111

e-mail [info@finland.lewmar.com](mailto:info@finland.lewmar.com)