



1. Ankerwinden

V1/V2/V3 Vertikal Ankerwinden

V1/V2/V3 Schalter Kits und Zubehör

4 Sicherungsautomaten



PART NO.	DESCRIPTION	FIT WINDLASS
68000348	Circuit Breaker 50A	V2 24V
68000349	Circuit Breaker 90A	V1/2 12V - V3 24V
68000350	Circuit Breaker 110A	V3 12V - V4/V5 24V
68000351	Circuit Breaker 150A	V4/V5 12V - V6 24V - V8 2.5kW
68000894	Circuit Breaker 200A	V8 3.5kW

5 Relais



PART NO.	DESCRIPTION	V1	V2/V3
Sealed Contactors			
68000937	Compact Dual 12V	•	•
68000938	Compact Dual 24V		•
68000318	Dual 12V	•	•
68000319	Dual 24V		•
Contactors in Boxes			
68000129	Dual 12V	•	•
68000130	Dual 24V		•

6 Schalter und Zubehör

Für Schalter und Zubehör Optionen siehe Seite 34



Fußschalter

Kettenzähler

Drahtlose ernbedienung

7 Optionales Zubehör



Führungsarm Kit
66810030



Manueller Handnotbetrieb
Nur Kettenspill: 66840054
Kettennuss und Verholspil: 66840056



Schottverschraubung
3 - fach 68000866



Windenkurbel
29140017

Abmessungs Diagramm

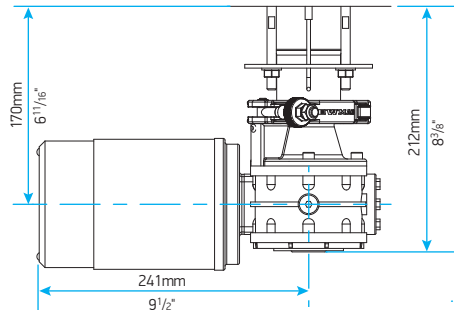
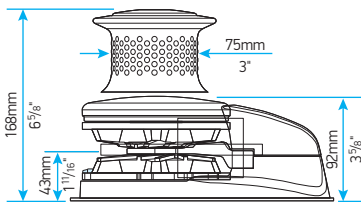

V1 Motor Getriebe (mit FastFit™)

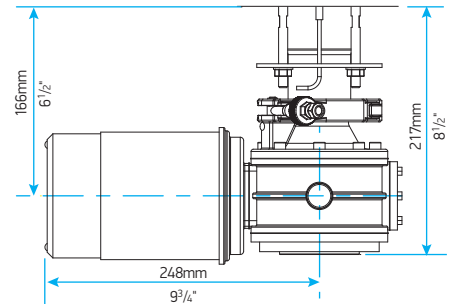

V2/V3 Motor Getriebe (mit FastFit™)

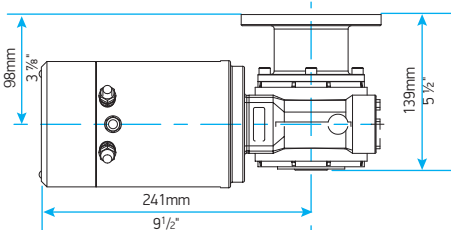
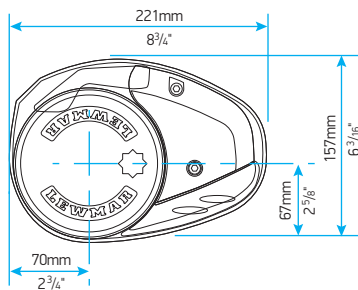

V1 Motor Getriebe (ohne FastFit™)

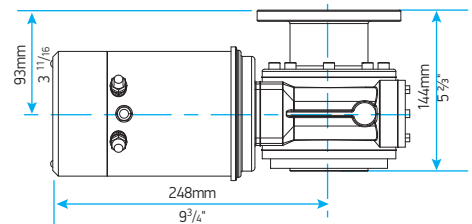

V2/V3 Motor Getriebe (ohne FastFit™)