

# **LEWMAR**

## **Flush Hatch Fitting & Adjustment Instructions**

*(To be retained in owner's manual for future reference)*

Flush hatches are for use on all craft types in accordance with **ISO/DIS 12216.2002, DESIGN CAT "A", AREAS IIa, III and IV**. Modification of the hatch by the fitting of vents etc. will invalidate the compliance with the standard.

### **Fitting Instructions**

Flush hatches should be fitted to a flat surface with a maximum tolerance of +/- 1mm and a minimum deck / hull thickness of 15. Check that all fastenings will be clear of deck moulding radii etc.

***Do not open and close the hatch more than necessary until the lower frame is securely mounted.***

The Flush Hatch must be fitted into a recess in the deck. The recess must be to the shape specified on Lewmar's drawings. The recess is normally included in the deck as part of the design process for the boat.

***The hatch should be mounted with minimum of 10mm between the hinge edge of the acrylic and the edge of the recess and a maximum 8mm radii at the base of the recess. See drawing below.***

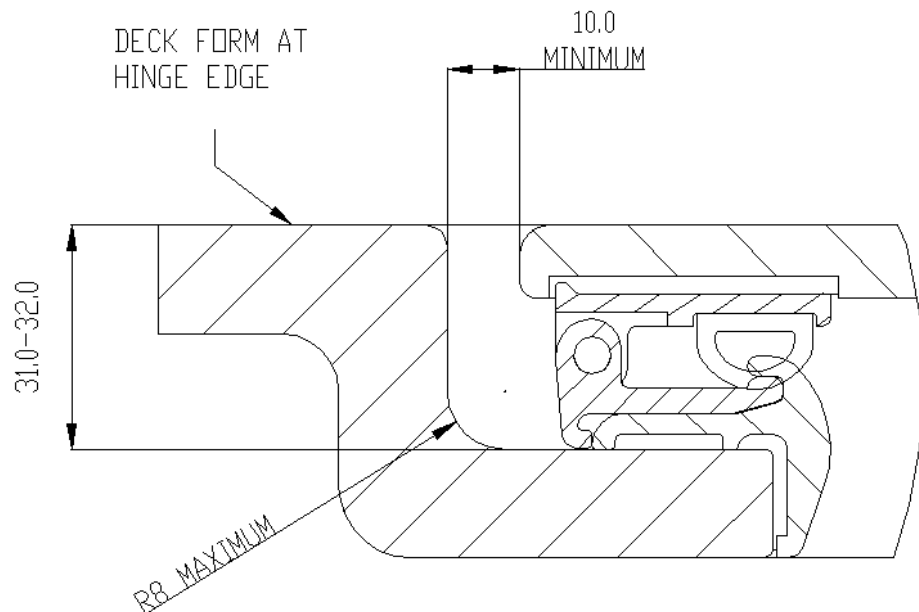

***It is essential that the lower frame is placed square on the deck opening. The operation of the hatch should be checked before sealing and fastening to the deck***

***When fitting a number of hatches it is advisable to prepare a template.***

Where the deck is of composite construction, it is recommended that the exposed laminate be sealed with the appropriate material prior to fitting the hatch. Openings cut in metal decks should have all burrs and sharp edges removed.

***Hatches should not be considered as stiffening members and it is recommended that the deck be adequately stiffened to prevent distortion during heavy weather.***

Re-check the frame on aperture and then apply bedding compound to the channel in lower frame. Bedding compound must have good adhesive qualities (e.g. silicone sealant), be a suitable grade for marine sealing applications, of 3mm minimum thickness and compressible to allow the lower frame to be pulled down in contact with the deck by the securing screws.

Position lower frame over hole and drill two fixing screw holes in opposite corners. Insert appropriate stainless steel fasteners (see below).

**Deck type**

Wood	M5 through bolts or marine grade wood screws.
GRP/Steel/Al Alloy	M5 through bolts or machine screws into suitable tapped plates.
Fixing Sizes	M5, 10UNC, 2BA, 3/16", Wood screws (min. length 40mm).
Hinge Fixings	M6 or 1/4" through bolts only.

Drill remainder of holes and fasten down from the center working out to the edges. Clean off surplus sealant.

***Through bolts should be used where fixings pass through lower hinges (M6 or 1/4" only).***

Once installed check again for correct operation of the hatch lid, i.e. closing/locking, even pressure of seal etc.

## **User Notes**

The locking ventilation position is used by closing the handles into the catch block center slot. Care should be taken not to stand on or load the hatch lid in this position, as damage could occur to the handle or catch block.

Always wash the hatch with soap, water and a soft cloth.

***Never use abrasive or solvent cleaners on the acrylic lid, as this may at a later date damage the acrylic.***

***To avoid risk of injury care should be taken to keep hands and limbs clear of lever and lid pinch zones while operating and adjusting the hatch.***